

APPLICATIONS

Nissan Maxima 2007

(without navigation)



KIT FEATURES

- DIN Mount Radio Provision with Pocket
- ISO Mount Radio Provision with Pocket
- Double DIN Mount Radio Provision
- Stacked ISO Units Provision

KIT COMPONENTS

- A) Radio Housing • B) Radio Housing Trimplate • C) Radio Housing Brackets
• D) Double DIN Trim Plate • E) (4) #8 3/8" Screws • F) ISO Brackets

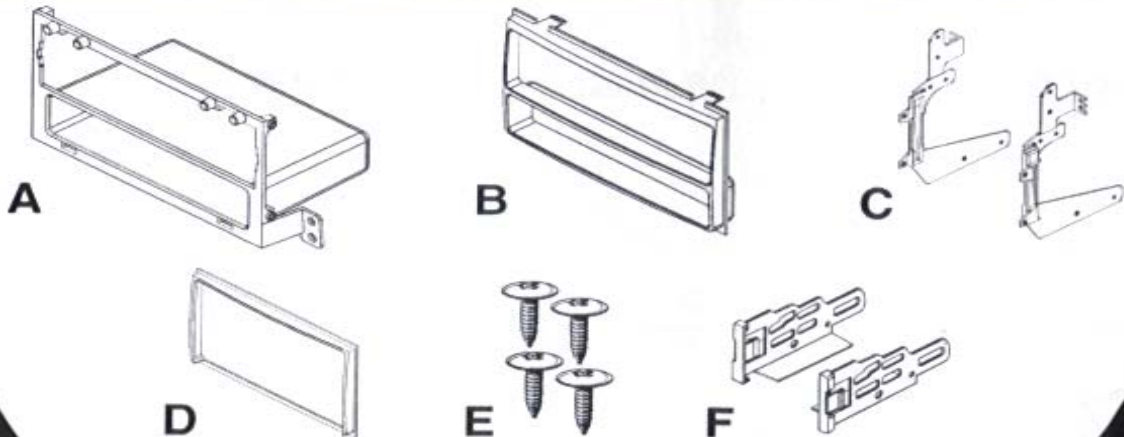

TOOLS REQUIRED:

- Small Flat Blade Screwdriver/ Panel Removal Tool
• Phillips Screwdriver • Torx Driver • Socket Set



TABLE OF CONTENTS

Dash Disassembly

- ***Nissan Maxima 2007*** **1,2**

Kit Assembly

- ***DIN Mount Radio Provision with Pocket*** **3**
- ***ISO Mount Radio Provision with Pocket*** **4**
- ***Double DIN Radio Provision*** **5**
- ***Stacked ISO Units Provision*** **6**

- Final Assembly** **7**

***Note:**

Refer also to the instructions included with the aftermarket radio.

NISSAN MAXIMA 2007

- 1 Disconnect the negative battery terminal to prevent an accidental short circuit.
- 2 Unlock the collar below shifter knob by turning collar counter clockwise and slide collar down. Using a small screwdriver or hook tool remove the spring clip to release and remove the shifter knob. (Figure A)
- 3 Unclip center console trim panel around shifter including a/c controls. Unplug and remove center console trim panel. (Figure B)
- 4 Remove (2) Phillips screws facing upward on bottom of trim panel surrounding the radio including the a/c vents. (Figure C)

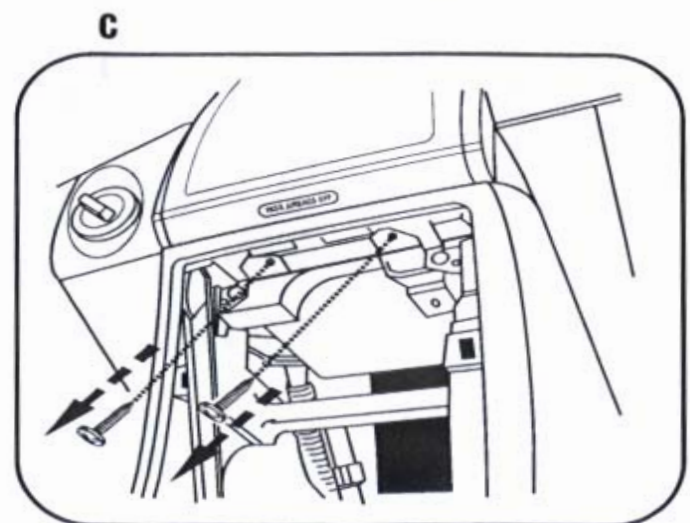
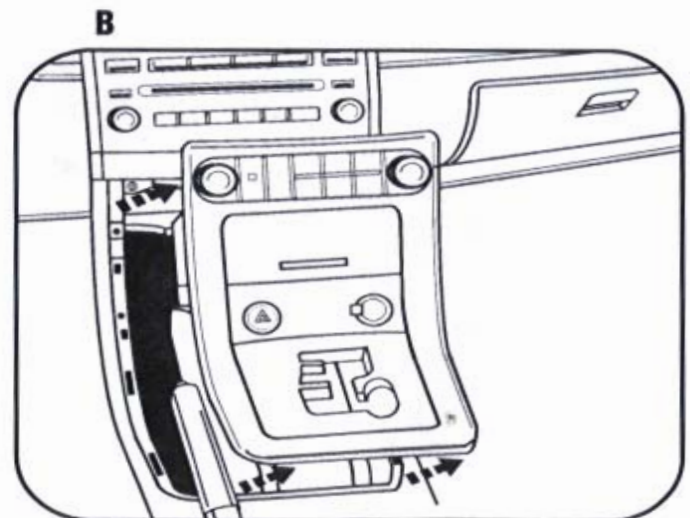
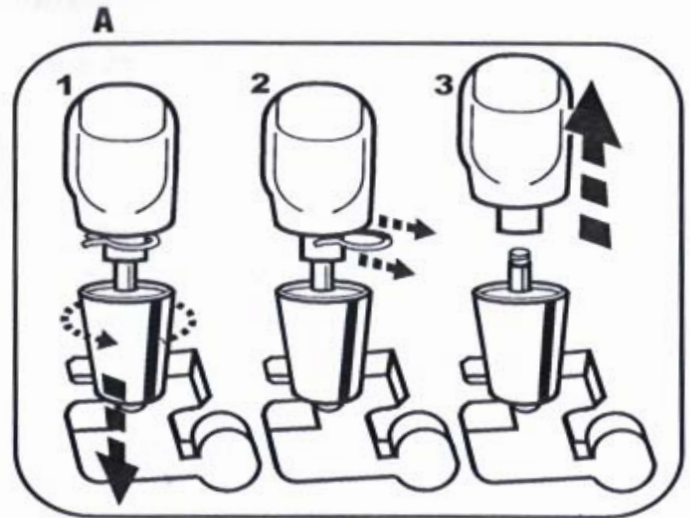

NISSAN MAXIMA 2007

- 5 Unclip and remove the trim panel surrounding the radio including the a/c vents. (Figure D)
- 6 Remove (4) Phillips screws securing the radio/display assembly. Unplug and remove the radio/display assembly. (Figure E)
- 7 Remove (2) Phillips screws and (5) Torx screws (per side) securing the factory brackets to the radio/display assembly. (Retain screws, factory brackets, 2 displays and A/C amplifier for use during kit assembly.) (Figure F)

Continue to kit assembly.

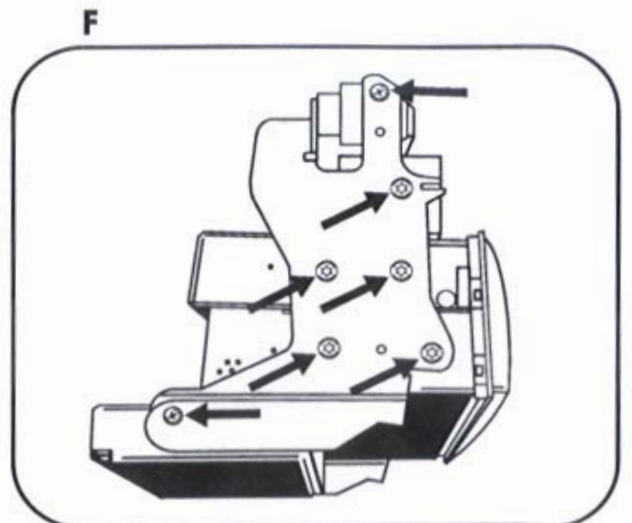
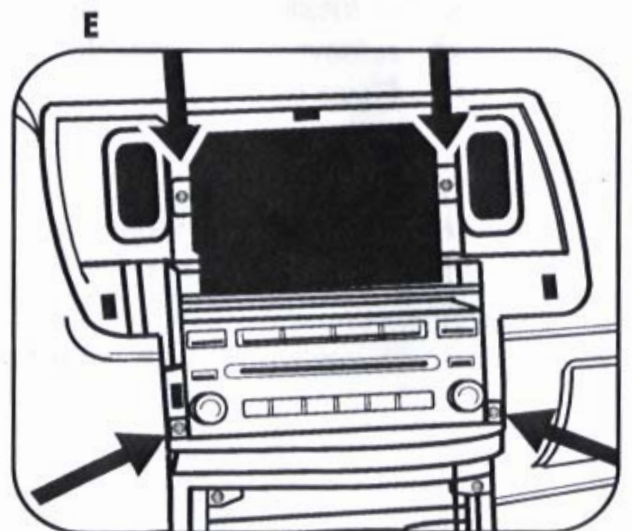
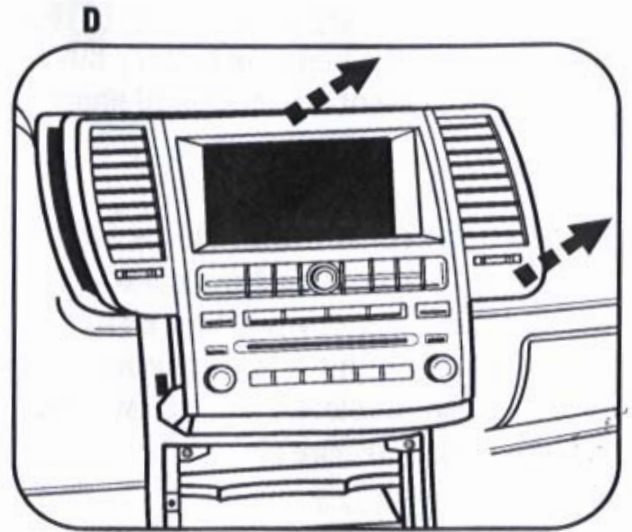

DIN RADIO PROVISION WITH POCKET

**Note: Refer also to the instructions included with the aftermarket radio.*

- 1 Attach the (2) radio housing brackets to the radio housing using the (4) #8 3/8" screws supplied with the kit. (Figure A)
- 2 Secure the 2 displays and A/C amplifier into the radio housing/bracket assembly using the factory hardware. (Figure B)
- 3 Slide the DIN cage into the Radio Housing and secure by bending the metal locking tabs outward. (Figure C)
- 4 Slide the aftermarket radio into the cage until it snaps into place. (Figure D)
- 5 Attach the radio housing trim plate supplied with the kit. (Figure D)

Continue to final assembly.

A

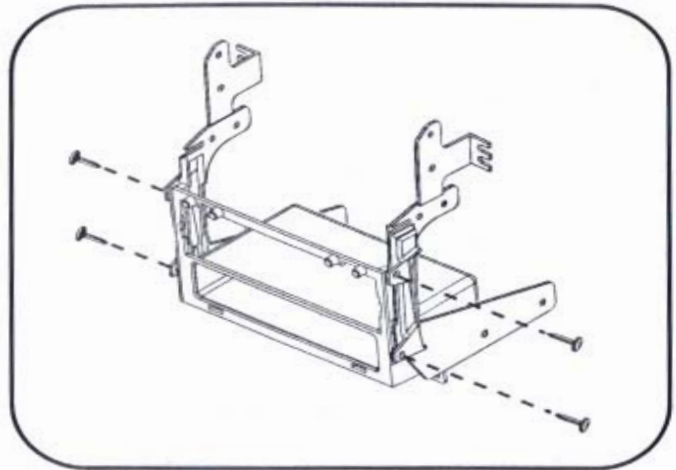

B

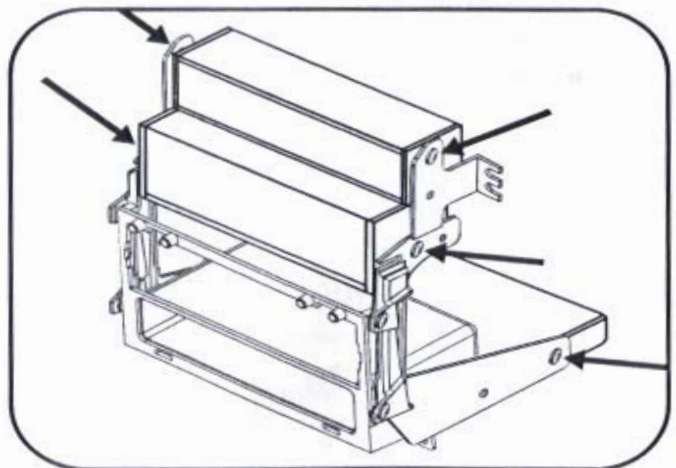

C

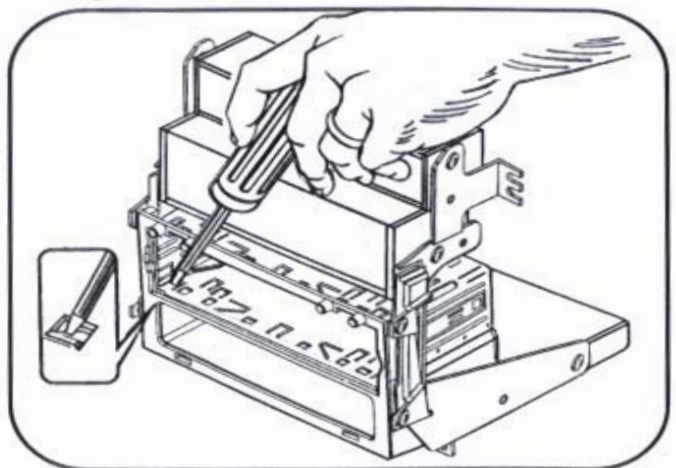

D

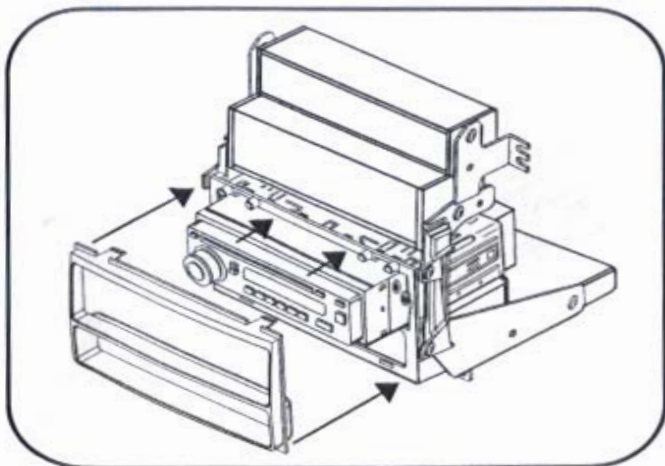

ISO RADIO PROVISION WITH POCKET

**Note: Refer also to the instructions included with the aftermarket radio.*

- 1 Attach the (2) radio housing brackets to the radio housing using the (4) #8 3/8" screws supplied with the kit. (Figure A)
- 2 Secure the 2 displays and A/C amplifier into the radio housing/bracket assembly using the factory hardware. (Figure B)
- 3 Mount the ISO Brackets to the aftermarket radio using the screws supplied with the radio. (Figure C)
- 4 Slide aftermarket radio into the radio housing until the side clips engage. (Figure D)
- 5 Attach the radio housing trim plate supplied with the kit. (Figure D)

Continue to final assembly.

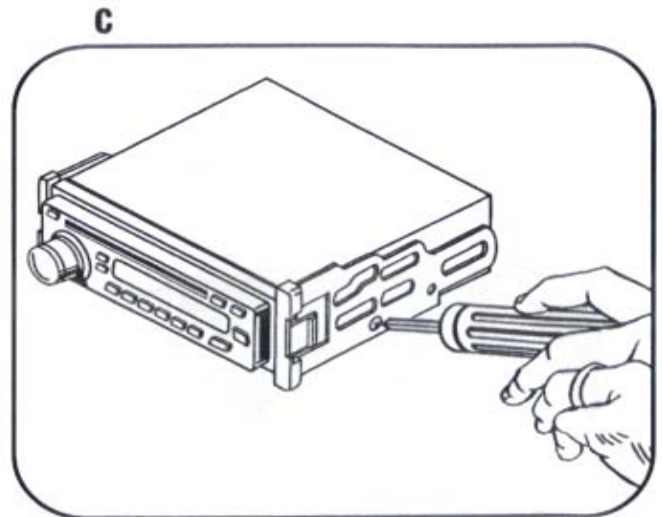
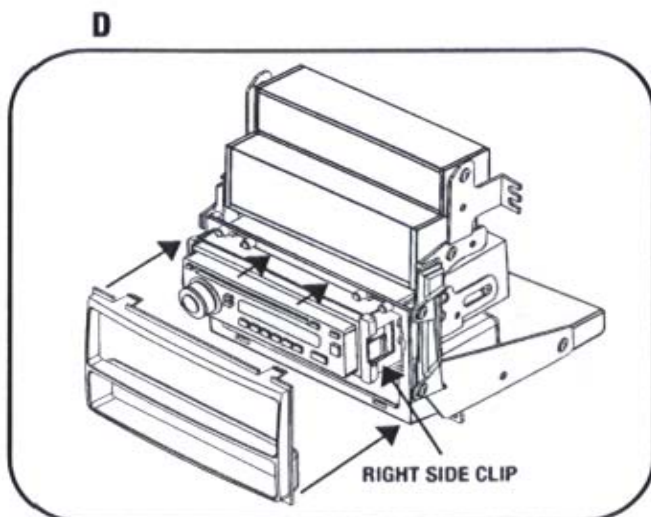
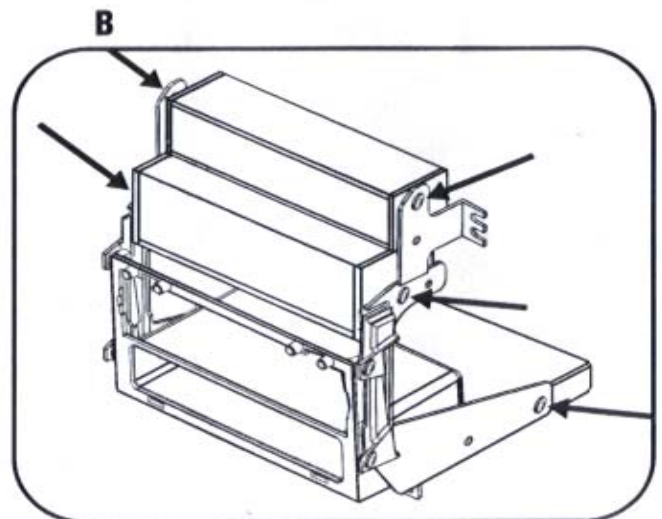
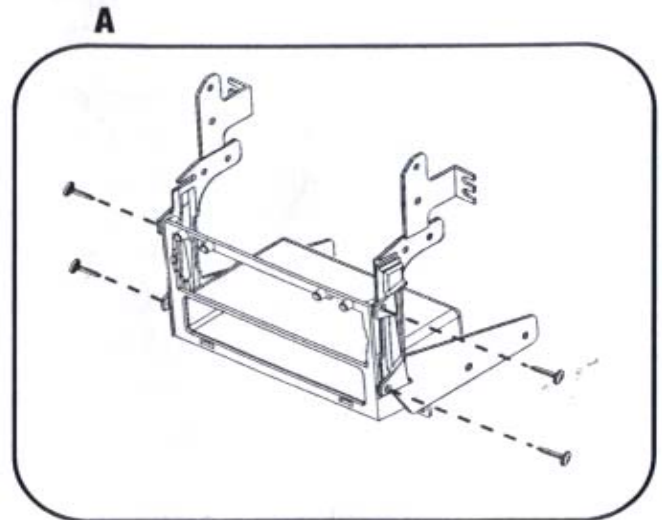

DOUBLE DIN MOUNT RADIO PROVISION

**Note: Refer also to the instructions included with the aftermarket radio.*

- 1** Re-attach the factory brackets to the 2 displays and A/C amplifier using the factory hardware. (Figure A)
- 2** Slide the Double DIN radio into the factory brackets and secure the unit to the brackets using the screws supplied with the radio. (Figure B)
- 3** Place the Double DIN trim plate over the face of the aftermarket radio. (Figure B)

Continue to final assembly.

A

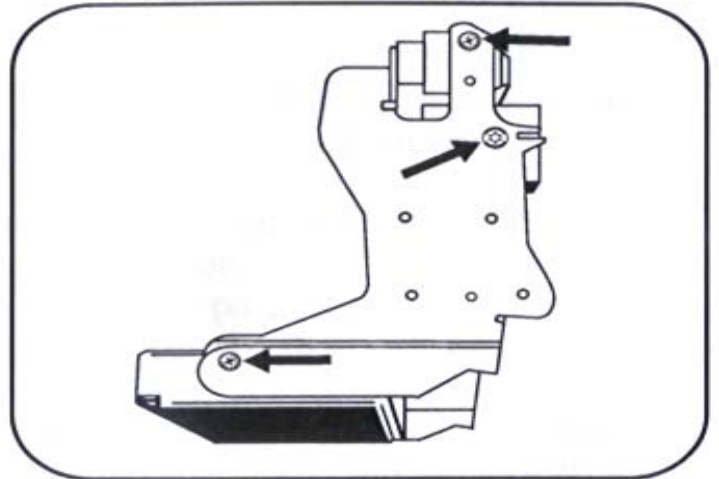

B

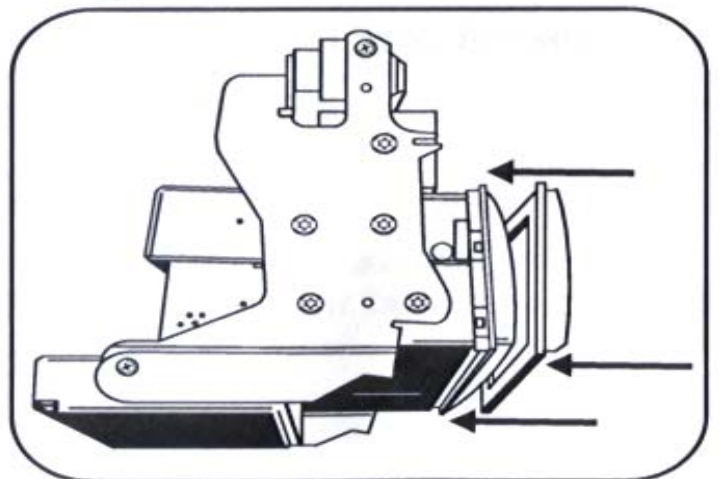

STACKED ISO UNITS PROVISION

**Note: Refer also to the instructions included with the aftermarket radio.*

- 1 Re-attach the factory brackets to the 2 displays and A/C amplifier using the factory hardware. (Figure A)
- 2 Slide the stacked ISO mount units into the factory brackets and secure the units to the brackets using the screws supplied with the units. (Figure B)
- 3 Place the Double DIN trim plate over the face of the ISO mount units. (Figure B)

Continue to final assembly.

