

APPLICATIONS Nissan Versa 2007

KIT FEATURES

- DIN Mount Radio Provision with Pocket
- ISO Mount Radio Provision with Pocket
- Double DIN Mount Radio Provision
- Stacked ISO Mount Units Provision



KIT COMPONENTS

A) Radio Housing • B) ISO Brackets • C) Trim Plate • D) Double DIN Trim Plate

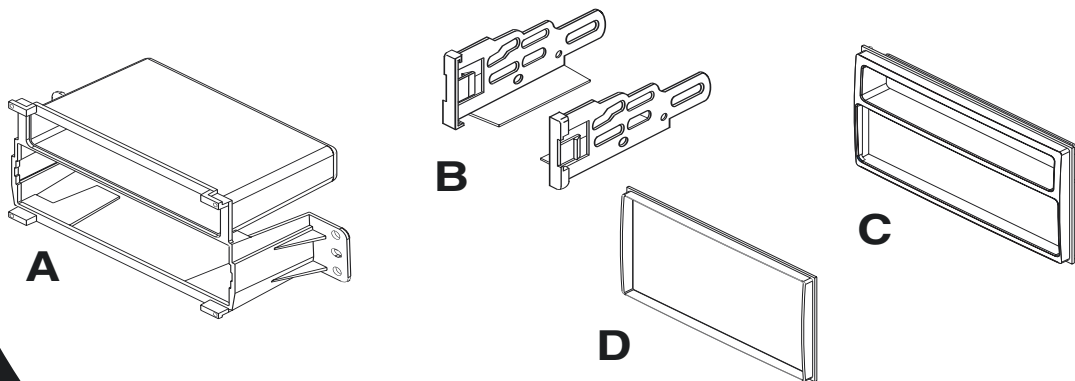

TOOLS REQUIRED:

- Small Flat Blade Screwdriver/ Panel Removal Tool
- Phillips Screwdriver



TABLE OF CONTENTS

Dash Disassembly

- Nissan Versa 2007 1,2

Kit Assembly

- DIN Mount Radio Provision with Pocket 3
- ISO Mount Radio Provision with Pocket 4
- Double DIN Mount Radio Provision 5
- Stacked ISO Units Provision 6

Final Assembly 7

***Note:**

Refer also to the instructions included with the aftermarket radio.

NISSAN VERSA 2007

- 1** Disconnect the negative battery terminal to prevent an accidental short circuit.
- 2** Unclip and remove the panel above the radio. (Figure A,B)
- 3** Remove (2) Phillips screws securing the radio trim panel then unclip and remove the entire panel surrounding the radio and a/c controls. (Figure C)

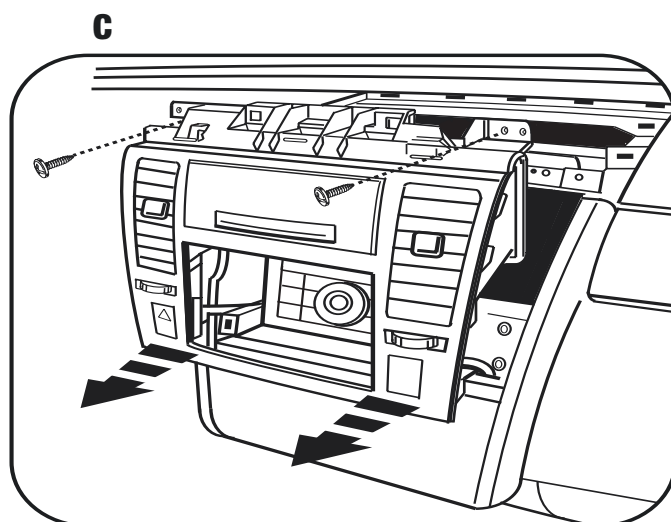
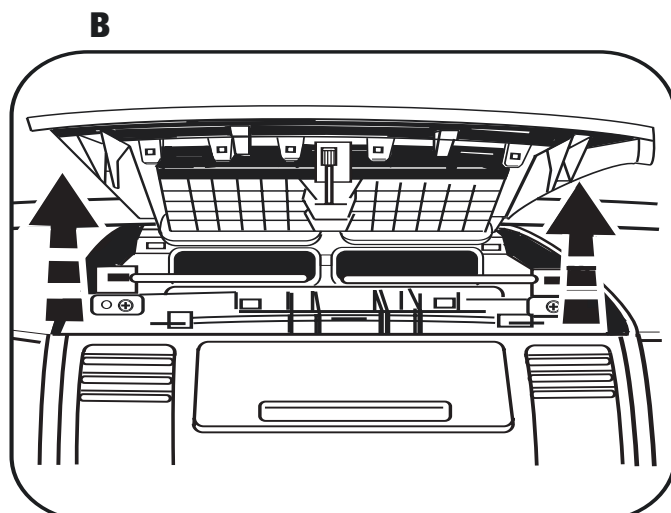
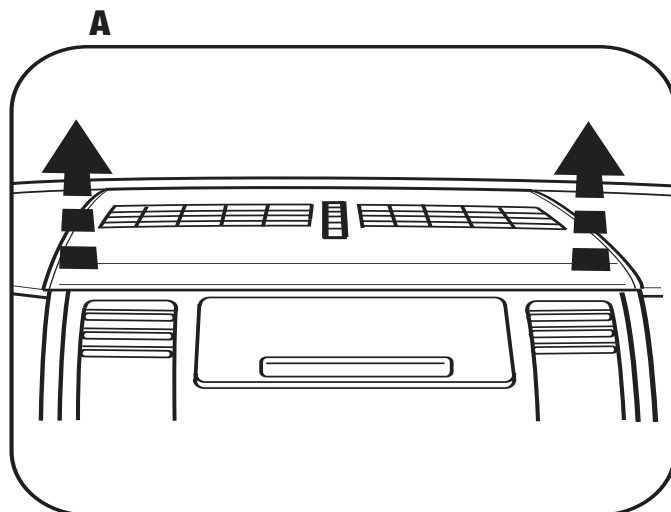

NISSAN VERSA 2007

4 Remove (4) Phillips screws securing radio, unplug and remove radio. (Figure D)

5 Remove (4) Phillips screws securing each bracket to factory radio. (Retain these brackets to be re-used during double DIN or stacked ISO kit assembly.) (Figure E)

Continue to kit assembly.

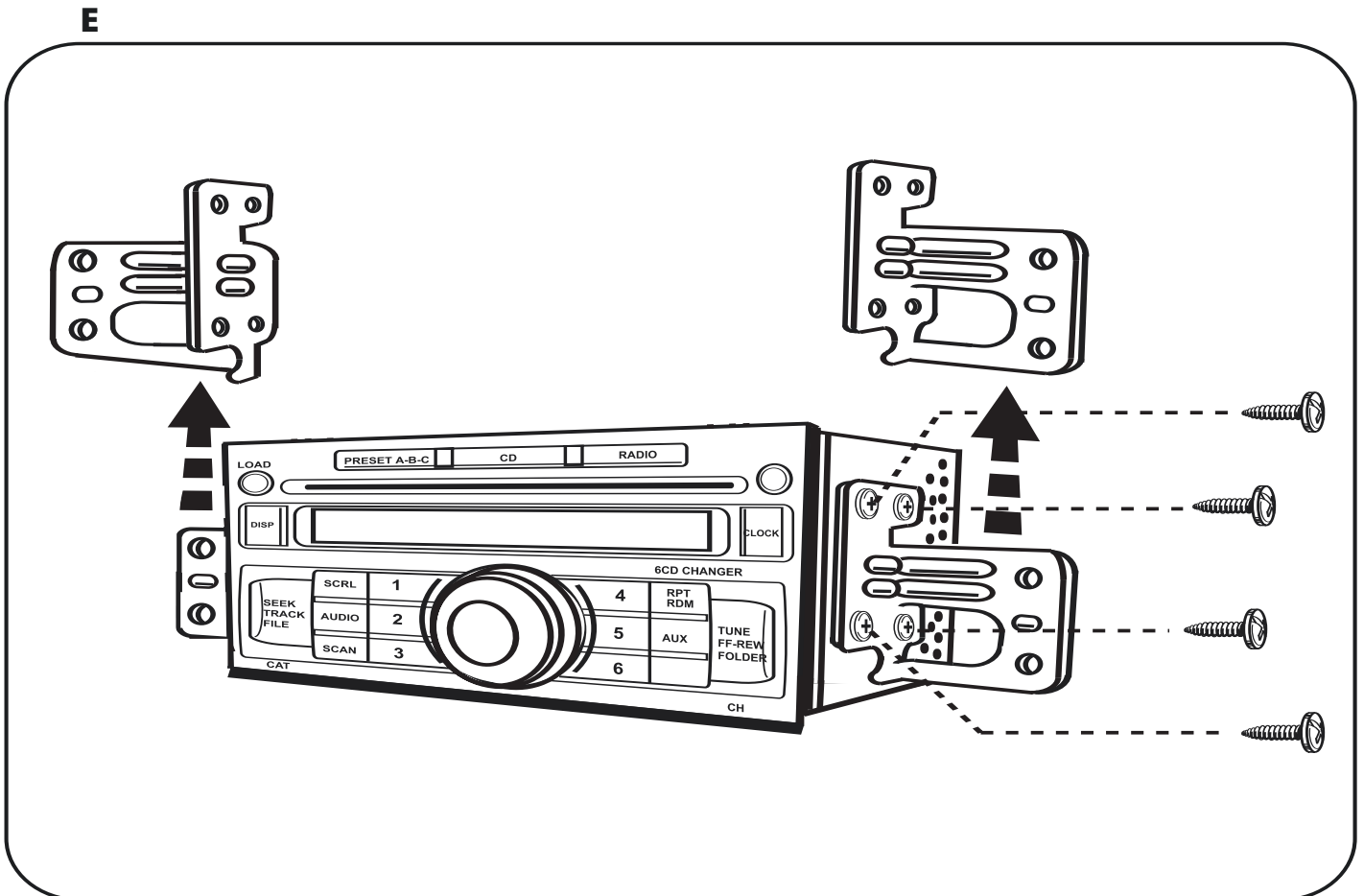
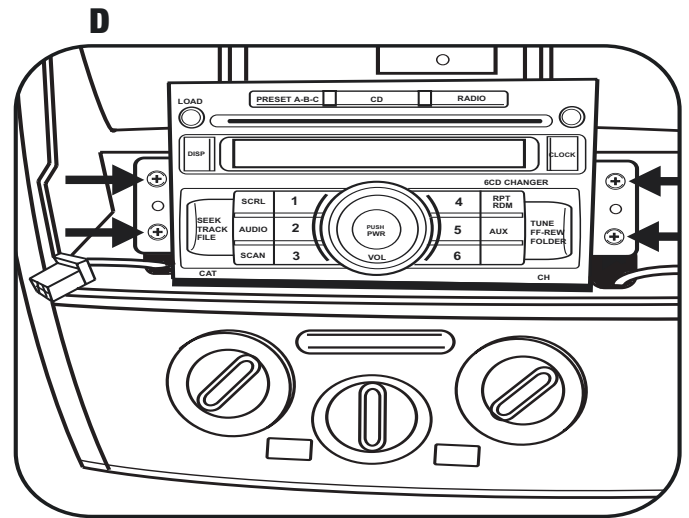

DIN MOUNT RADIO PROVISION

****Note: Refer also to the instructions included with the aftermarket radio.***

Note: *You will need to remove the aftermarket radio's trim ring if equipped.*

- 1** Slide the DIN cage into the Radio Housing and secure by bending the metal locking tabs outward. (Figure A)
- 2** Slide the aftermarket radio into the cage until it snaps into place. (Figure B)
- 3** Attach the trim plate supplied with the kit to the front of the radio housing assembly. (Figure B)

Continue to final assembly.

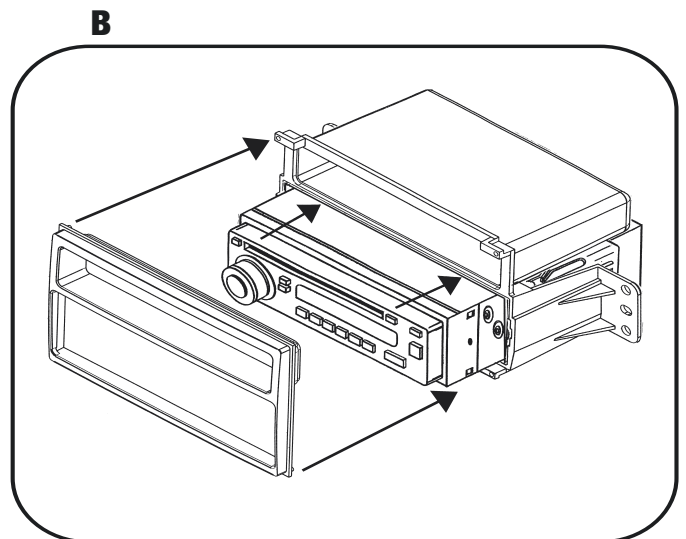
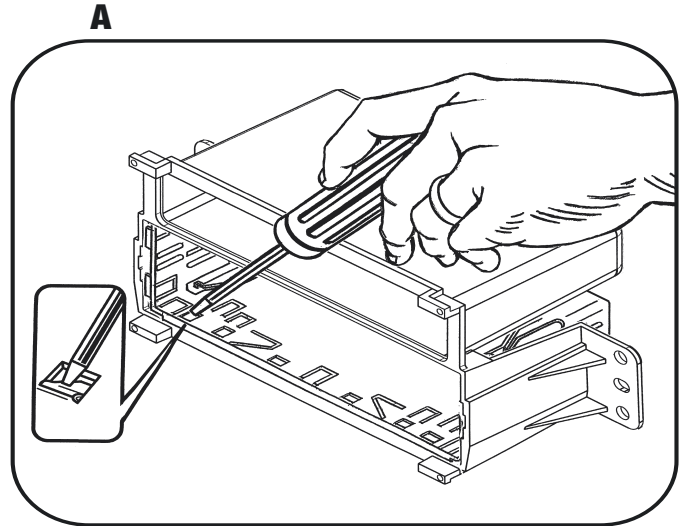

ISO MOUNT RADIO PROVISION

**Note: Refer also to the instructions included with the aftermarket radio.*

Note: *The following modification will need to be made to both ISO brackets when using the ISO mount radio provision. Cut or trim the area shown from the ISO bracket. (Figure A)*

- 1 Mount the ISO Brackets to the aftermarket radio using the screws supplied with the radio. (Figure B)
- 2 Slide the radio into the radio housing until it snaps into place. (Figure C)
- 3 Attach the trim plate supplied with the kit to the front of the radio housing assembly. (Figure C)

Continue to final assembly.

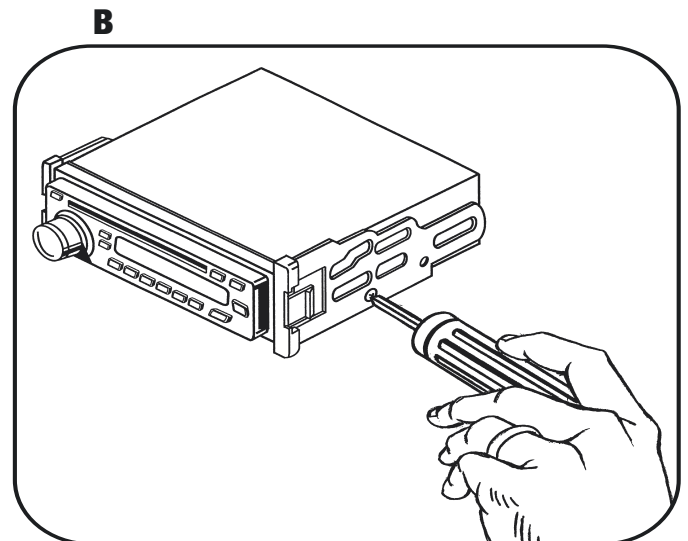
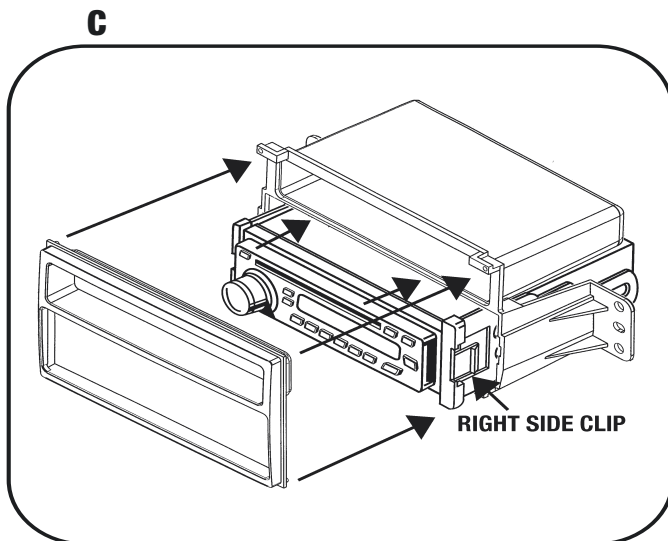
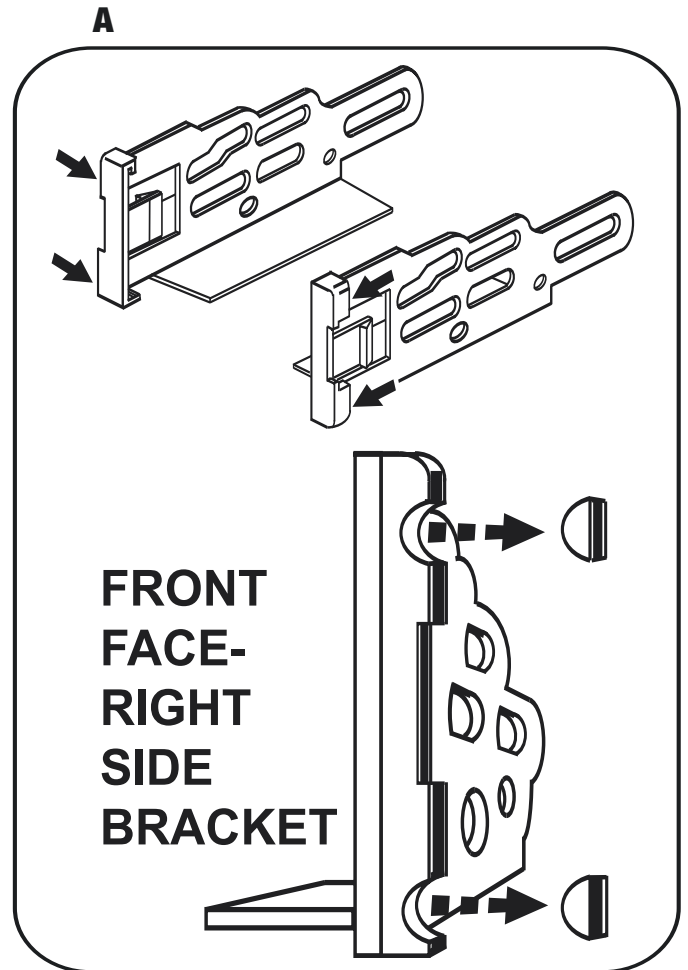

DOUBLE DIN MOUNT RADIO PROVISION

**Note: Refer also to the instructions included with the aftermarket radio.*

- 1** Mount the factory brackets (removed from factory radio during disassembly) to the sides of the double DIN radio using screws supplied with the double DIN radio. (Figure A)
- 2** Place the double DIN trim plate on the front of the double DIN radio. (Figure B)

Continue to final assembly.

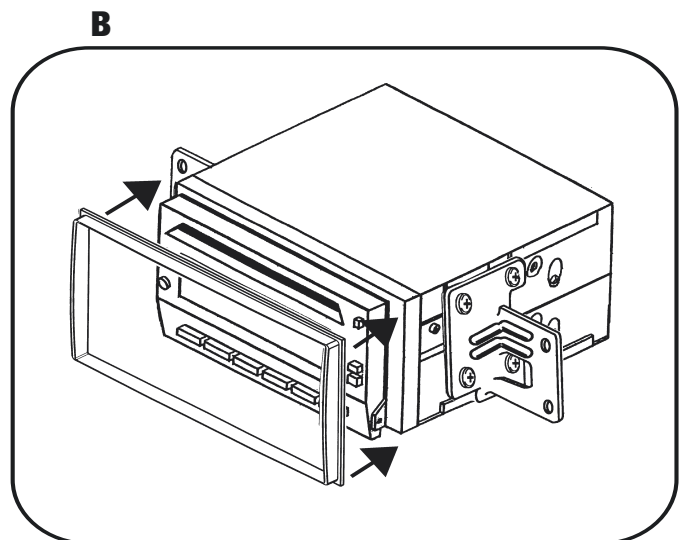
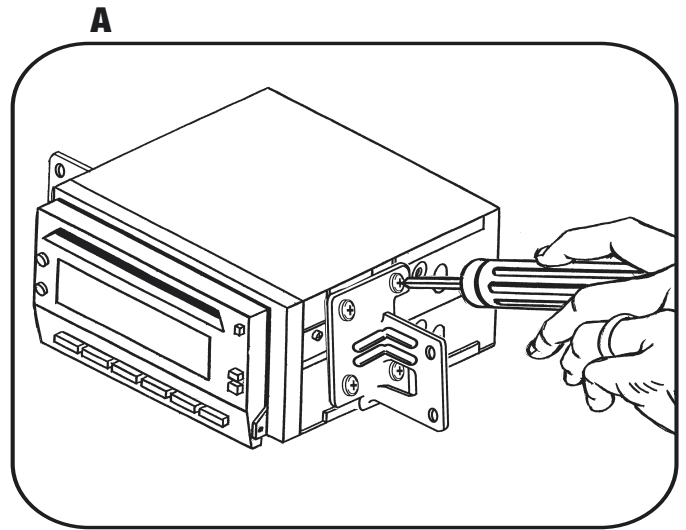

STACKED ISO UNITS PROVISION

**Note: Refer also to the instructions included with the aftermarket radio.*

- 1** Mount the factory brackets (removed from factory radio during disassembly) to the sides of the stacked ISO units using screws supplied with the ISO units. (Figure A)
- 2** Place the double DIN trim plate on the front of the stacked ISO units. (Figure B)

Continue to final assembly.

