

Clarion

2-DIN

BKX-1130-06

Installation manual for:

Honda Acura RSX 2002 -2004

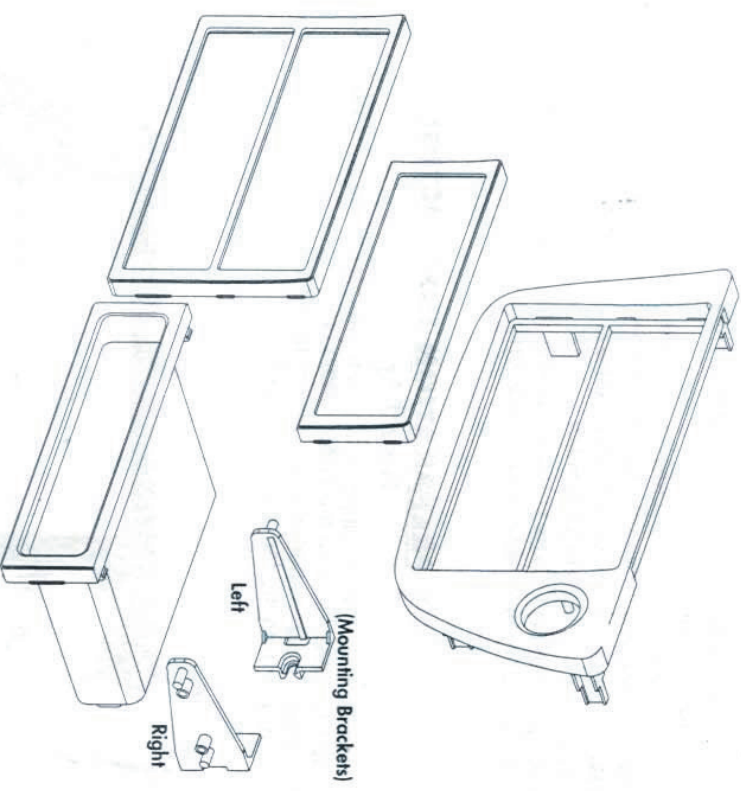

RADIO MOUNTING KIT INSTALLATION INSTRUCTIONS

DASH DISASSEMBLY & RADIO REMOVAL INSTRUCTIONS

- 1) Carefully unsnap and remove the dash panel directly below the factory radio, disconnect the wire harness from the panel and remove panel.
- 2) Remove the (2) Phillips screws located directly below the rear of the radio.
- 3) Carefully pry factory radio forward from the rear of the radio (CAUTION!!) Prying from the face of the factory radio without pulling radio forward from below may damage the factory radio fascia.
- 4) Remove radio from dash cavity.
- 5) Disconnect wire harnesses and antenna lead from radio and Hazard switch, then remove radio.
- 6) Remove the (8) Phillips screws securing the factory radio to the metal support chassis. Then remove radio from chassis.
- 7) Remove the (2) screws securing the Hazard switch to the rear of the factory bezel and remove Hazard switch.
- 8) Remove the (4) Phillips screws securing the metal support chassis to the rear of the factory bezel and remove support chassis.

KIT PREPARATION INSTRUCTIONS

For All Applications

- 1) Re-attach the metal support chassis to the rear of the screws removed from the factory radio bezel. using the
- 2) Re-install hazard button to the rear of the removed from the factory radio bezel. using the screws

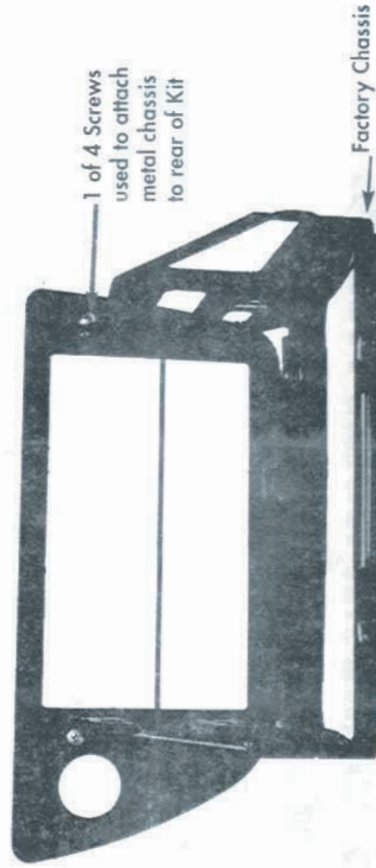

NOTES:

KIT ASSEMBLY INSTRUCTIONS

Single ISO Mount Applications

- 1) Prepare kit as shown under Preparation Instructions on page 1.
- 2) Attach left and right side pocket mounting brackets and secure to the rear of the pocket using screws supplied with kit.
- 3) Insert pocket into lower section of the main bracket and secure to the lower mounting holes of the metal support chassis using the Phillips screws removed from the sides of the factory radio.
- 4) Remove metal sleeve from aftermarket radio.
- 5) Insert aftermarket radio into upper location of kit and secure radio to metal chassis radio mounting hole locations.

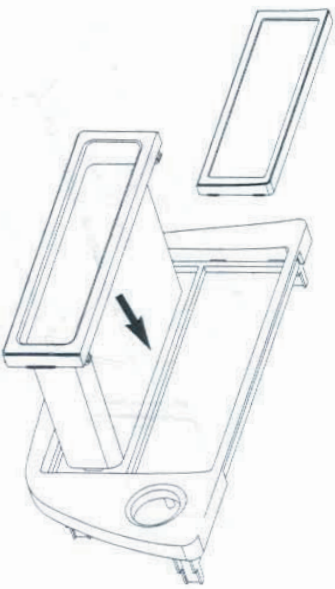

KIT ASSEMBLY INSTRUCTIONS

Double DIN & Double ISO Mount Applications

- 1) Prepare kit as shown under Preparation Instructions on page 1.
- 2) Cut and remove center rib from main bracket for double DIN and double ISO applications
- 3) For double DIN radio applications ONLY cut and remove center rib from and file edges smooth.
- 4) Remove metal sleeve from aftermarket radios (Double ISO applications only).
- 5) Insert aftermarket radio(s) into metal chassis support frame and secure using Phillips screws removed from the sides of the factory radio.
- 6) For Double DIN sized radios cut and remove center rib from the and file the edges smooth.

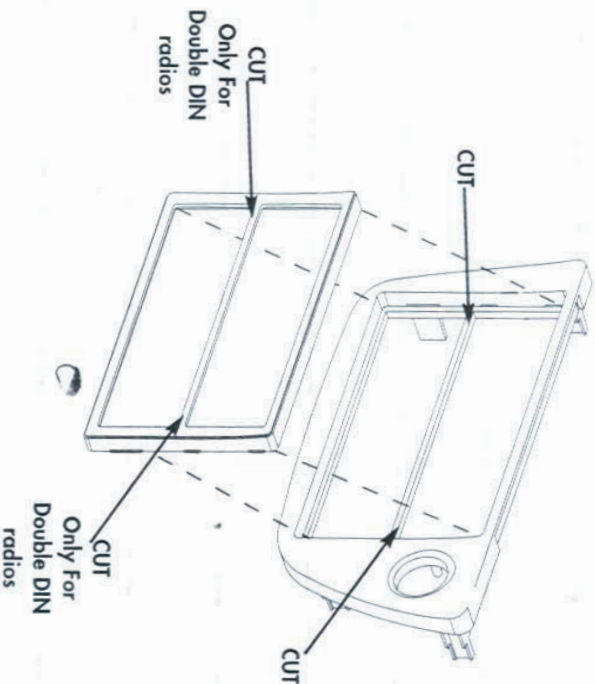

NOTES:

KIT ASSEMBLY INSTRUCTIONS

Single DIN Mount Applications

- 1) Prepare kit as shown under Preparation Instructions on page 1.
- 2) Attach left and right side pocket mounting brackets and secure to the rear of the pocket using screws supplied with kit.
- 3) Insert pocket into lower section of the main bracket and secure to the lower mounting holes of the metal support chassis using the Phillips screws removed from the sides of the factory radio.
- 4) Insert DIN sleeve (supplied with radio) from your new radio into the upper section of the installation kit.
- 5) Depress the tabs from inside the sleeves opening upward, outward, and downward to secure sleeve to the installation kit.
- 6) Install radio into sleeve and lock into place.
- 7) Attach a rear support bracket (supplied with most aftermarket radios) to the rear of the new radio and adjust as necessary to attach to the rear support stud located on the back of the pocket using (1) small phillips screw supplied with kit.

